

P SERIES

standard

FIRE HOSE REEL

Model 25/20/25/30 P (N)

Fire Hose Reel equipped with a manual control valve. The Fire Hose Reel is supplied with a wallmounting swinging arm, allowing the Hose Reel to swing through 180°, enabling the Hose to run in all directions.

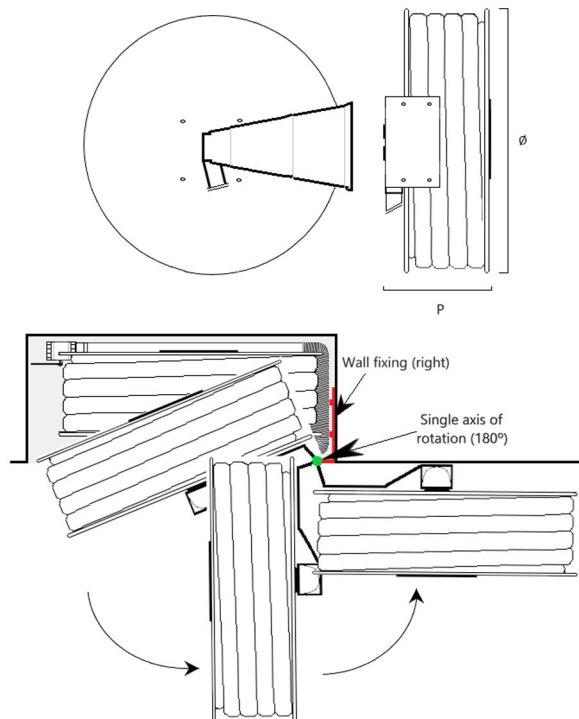

MODEL	HOSE		DIMENSIONS	HOLE DIMENSIONS	REFERENCE
	Ø	Length	Ø x P	W x H x D	
25/20 P (N)	25mm	20m	550 x 220mm	650 x 650 x 240mm	301023
25/25 P (N)	25mm	25m	550 x 220mm	650 x 650 x 240mm	301011
25/30 P (N)	25mm	30m	550 x 260mm	650 x 650 x 280mm	301042

technical features

Models	25/20 P (N), 25/25 P (N) and 25/30 P (N)
Certificate	According to EN 671-1:2012
Fire Hose Reel	Steel discs Ø550mm - 1,2 mm Centre parts made of Brass Swinging arm support - Swinging angle of 180° 1,10 mt supply hose including spiral spring Powder paint finished RAL 3000 Corrosion treatment Electrostatic powder painting - min. 70 micron
Hose	Ø 25mm, according to EN 694
Nozzle	Three positions (Shift-off / jet / spray) Ø 10mm Factor K = 42
Stop valve	1" manual stop valve

OPTIONS:

Hinges:	Pressure gauge:	Hose:
<input type="checkbox"/> Left	<input type="checkbox"/> 0 - 25 bar	<input type="checkbox"/> Textile coating