

IM/P SERIES

standard

HOSE REEL FOR INDUSTRIAL MAINTENANCE

Model: 25/20/25/30 IM/P

Hose Reel equipped with a manual stop valve. The fire hose reel is supplied with a fixed wall mounting bracket which simplifies its installation, including omnidirectional guide for hose unwinding.

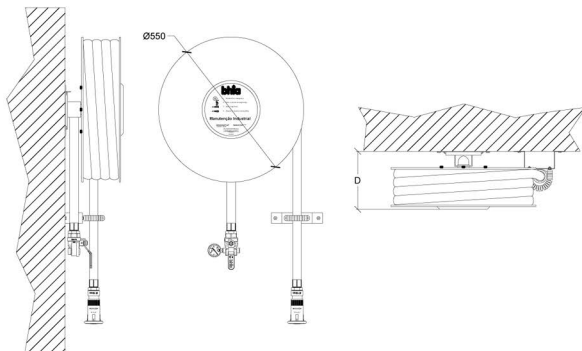

Technical features

Model	20 IM/P, 25 IM/P, 30 IM/P
Fire Hose Reel	Steel side discs Ø550mm - 1,2 mm Centre parts made brass Fixed wall-mounting 1,10 mt supply hose including spiral spring Powder paint finished RAL 6024 Corrosion treatment Electrostatic powder painting - min. 70 micron
Hose	Ø 25mm, according to EN 694:2014
Nozzle	Three positions (Shif-off/jet/spray) Ø 10mm Fator K = 42
Stop valve	1" manual stop valve

MODEL	HOSE		DIMENSIONS	REFERENCE
	Ø	Length	Ø x D	
25/20 IM/P	25mm	20m	550 x 220mm	700501
25/25 IM/P	25mm	25m	550 x 220mm	
25/30 IM/P	25mm	30m	550 x 260mm	

OPTIONS:

Pressure gauge:

0 – 25 bar